



Upgrade your scrap cutting operation



- Tired of smoke hanging over your facility?**
- Can't cut scrap during the day?**
- Tired of neighbors complaining?**
- Striving to be more environmentally friendly?**

Imperial Systems' Radial Air Management (RAM) system is the new, innovative solution on the market. This system moves with your cutting operation to extract smoke at the point of creation, ensuring optimal efficiency and improving air quality.

Contact Imperial Systems for more information.

800.918.3013 or www.ImperialSystemsInc.com

RAM



RADIAL AIR MANAGEMENT SYSTEM

Key Advantages of RAM System from Imperial Systems

- Radial hood moves 180°
- Allows you to cut and stage at the same time
- Inline Spark Trap to prevent fires in dust collector
- Can be installed inside or outside
- Robust construction allows for easy set up and tear down for temporary scrap cutting applications
- Hood floats above the scrap and is not in the way of the loader. Other systems with permanently placed hoods get destroyed from loader operator
- Hood walls can be flexible or rigid for different applications
- Powered wheels allow the operator to move the hood by pendant
- Different hood sizes available per customers request

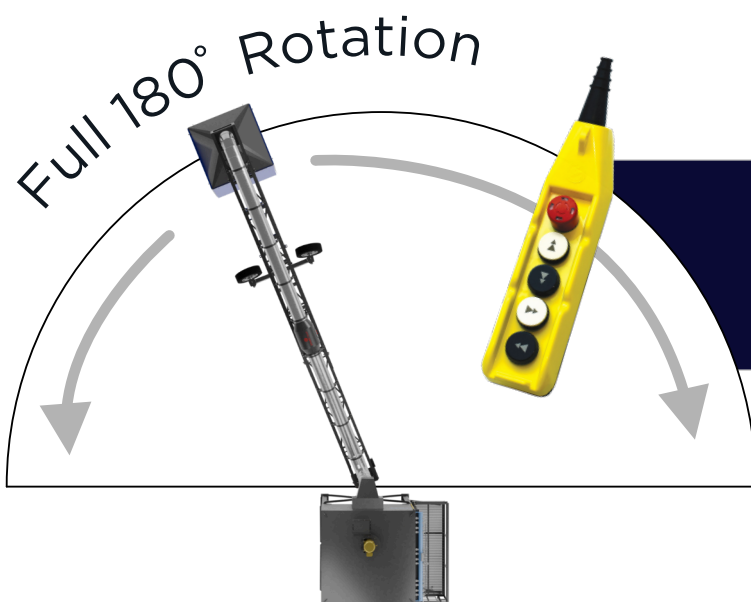

Pendant controller allows hood to remotely be moved 180° left or right, or raised and lowered.



7320 W. Market St, Mercer, PA 16137
www.ImperialSystemsInc.com | 800.918.3013