

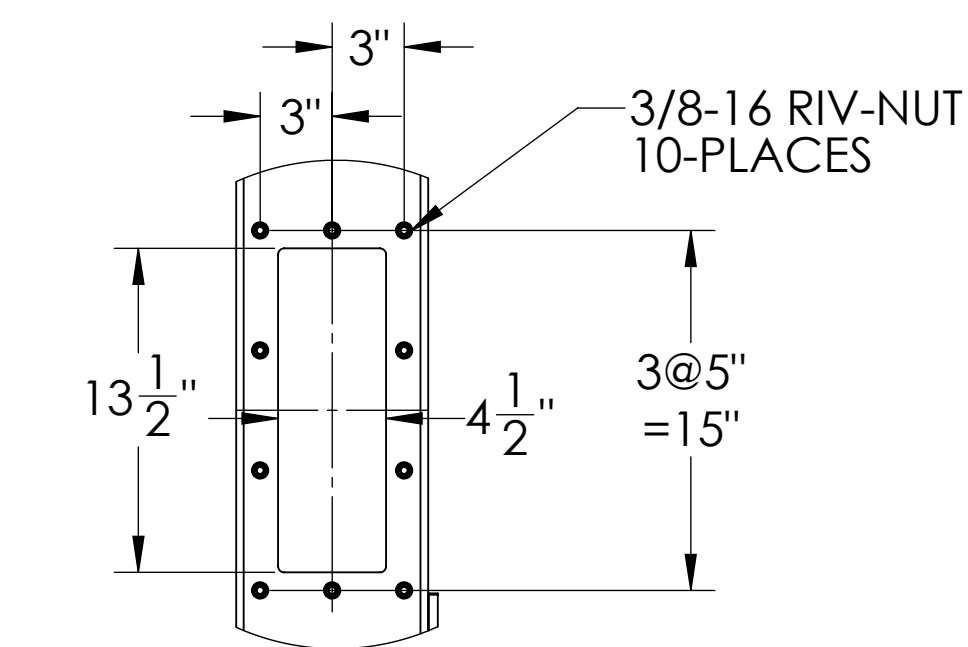

FOOT PRINT  
SECTION A-A



DISCHARGE FLANGE  
DETAIL B  
SCALE 1 : 8

\*OPTIONAL CRANE SLOTS, CURTAIN STRIPS & LIGHT FIXTURE AVAILABLE.

THIS DRAWING IS A CONFIDENTIAL DISCLOSURE AND IS LOANED TO RECALL AT ANY TIME WITH THE UNDERSTANDING THAT IT WILL NOT BE USED IN ANY WAY DETRIMENTAL TO THE INTERESTS OF IMPERIAL SYSTEMS.

DESIGN DATA:	HOOD VOLUME: 550 CU.FT. AIR FLOW: 850 CFM	DRAWN BY	SAS	DATE	11/19/20	WEIGHT (lbs)	
PAINT COLOR:		IMPERIAL FLAT BLACK		 7320 W. MARKET ST. MERCER, PA 16137 T: 724-662-2801 F: 724-662-2803 www.isystemsweb.com		<b>AIRPORT</b> 12FT X 5FT X 8FT	
FINISH:		ALL SHARP EDGES TO BE ROUNDED TO A SMOOTH RADIUS. ALL BURRS, WELD SPATTER AND ALL OTHER SHARP PROJECTION TO BE GROUND SMOOTH.					
UNLESS OTHERWISE SPECIFIED:		TOLERANCES UNLESS OTHERWISE INDICATED					
1. NO BURRS OR SHARP EDGES		.0 ± .020		FRACTIONS: ± 1/8			
2. MACHINED SURFACES 125 Ra, DRILLED HOLES 250 Ra		.00 ± .010		ANGULAR: ± 1°			
SCALE	1:24	DO NOT SCALE DRAWING		SHEET	1 OF 1	DRW. NO.	AP120508