

8 7 6 5 4 3 2 1

D  
C  
B  
A

D  
C  
B  
A

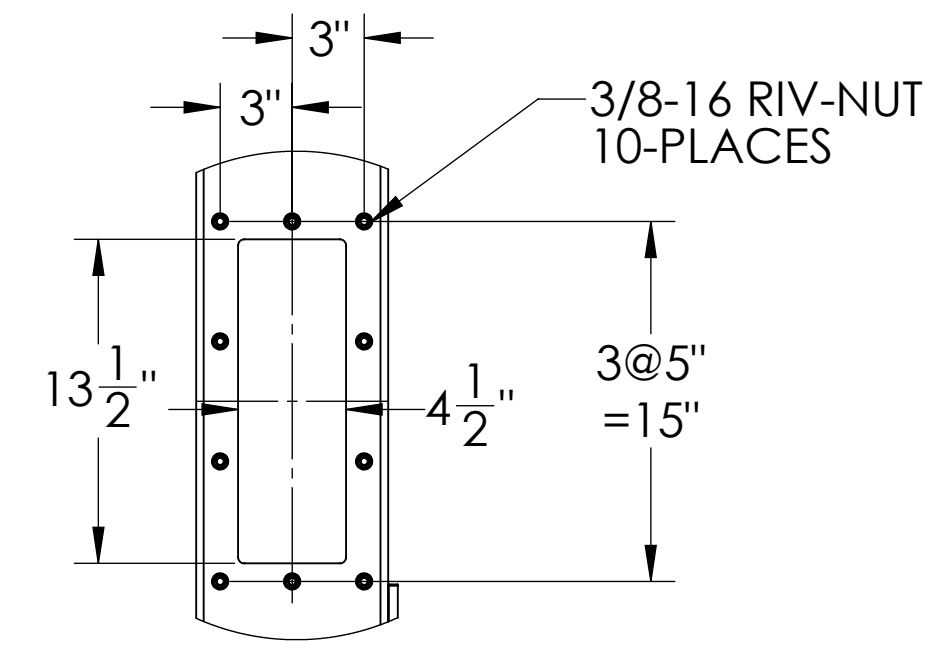
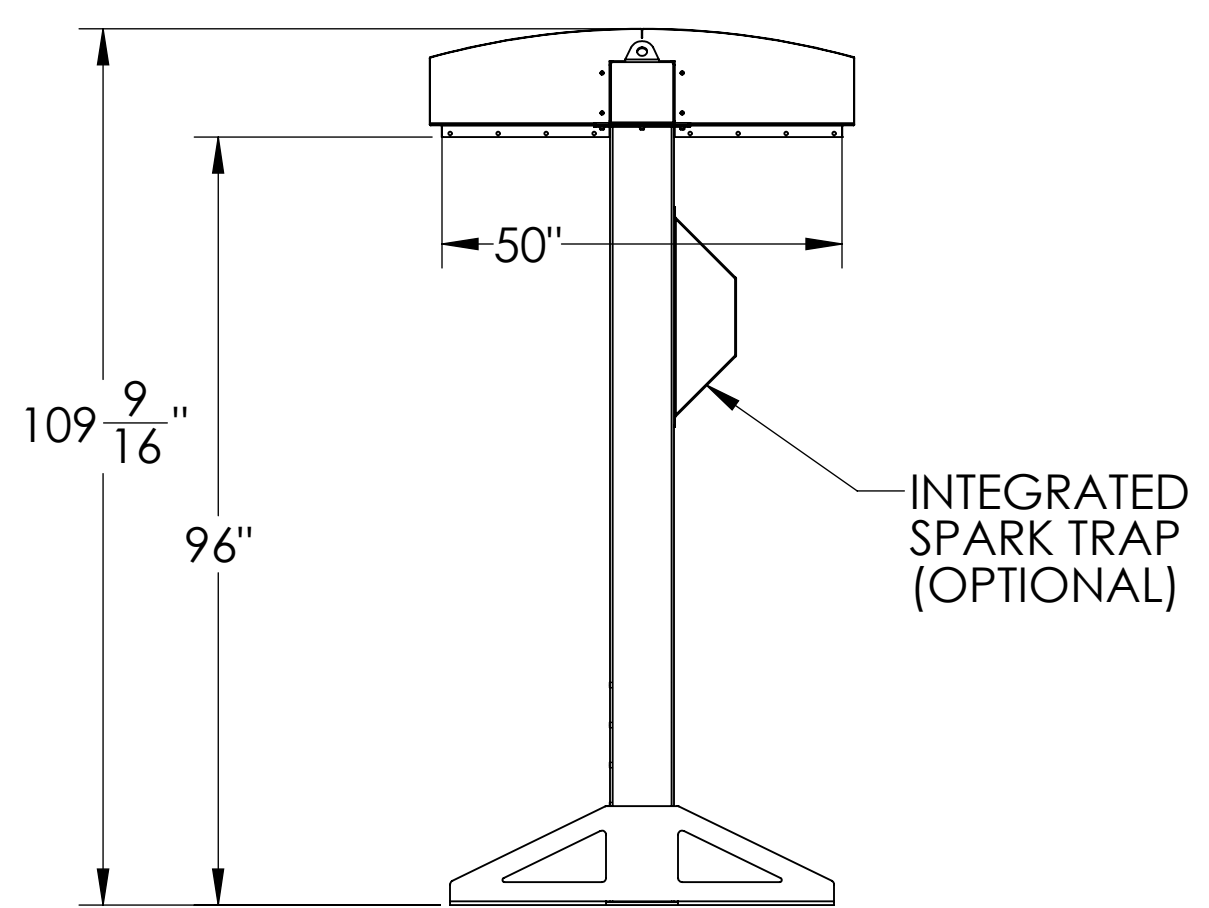
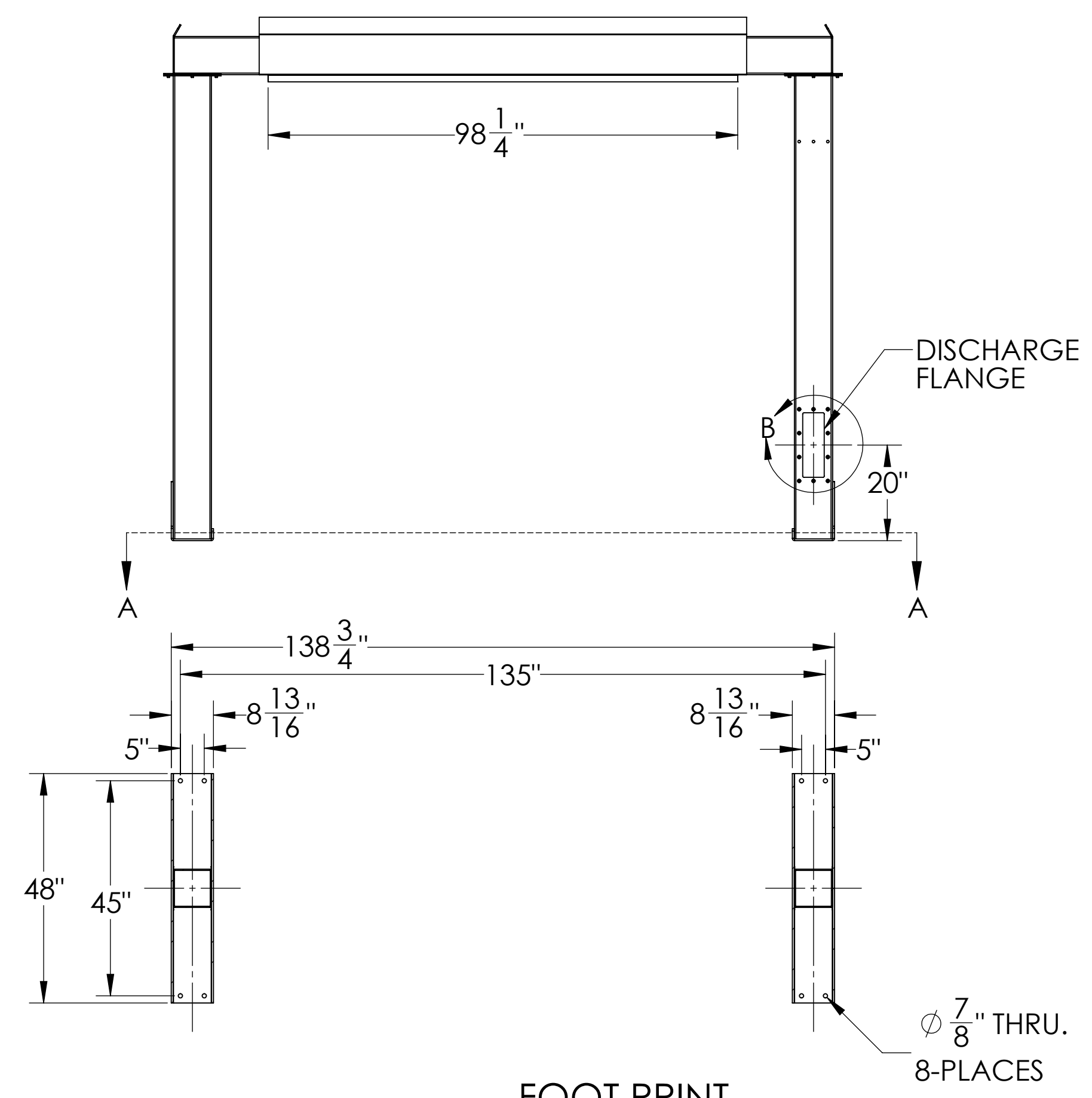
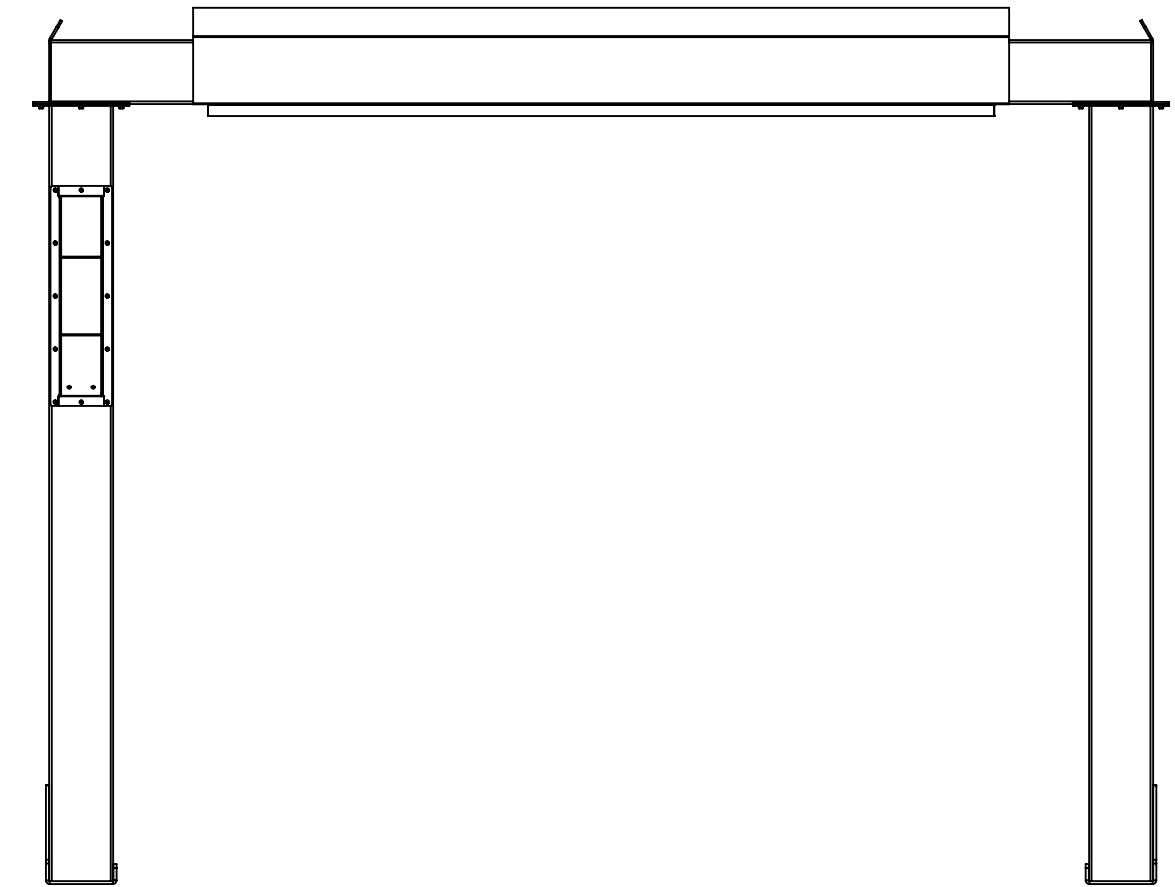
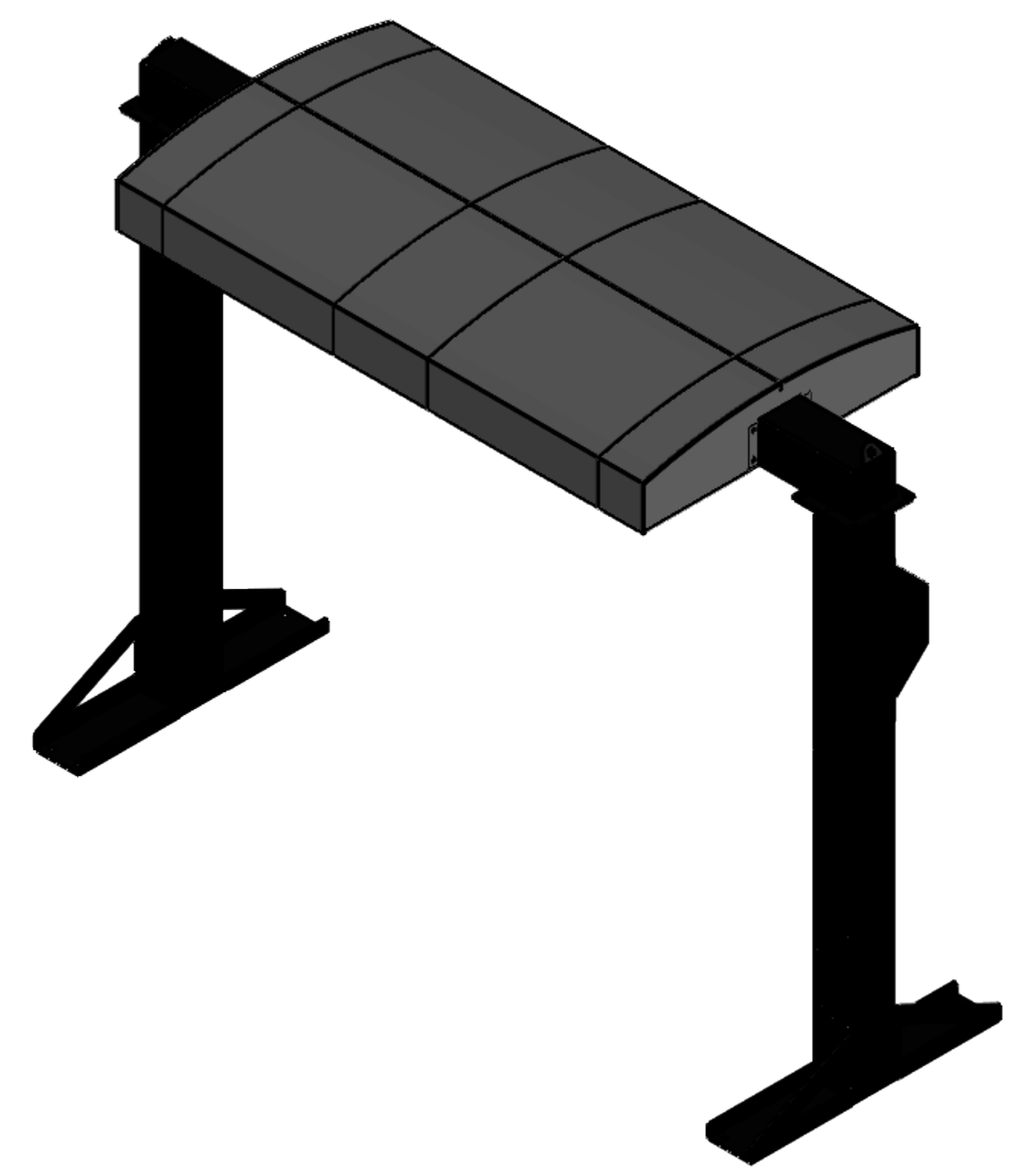
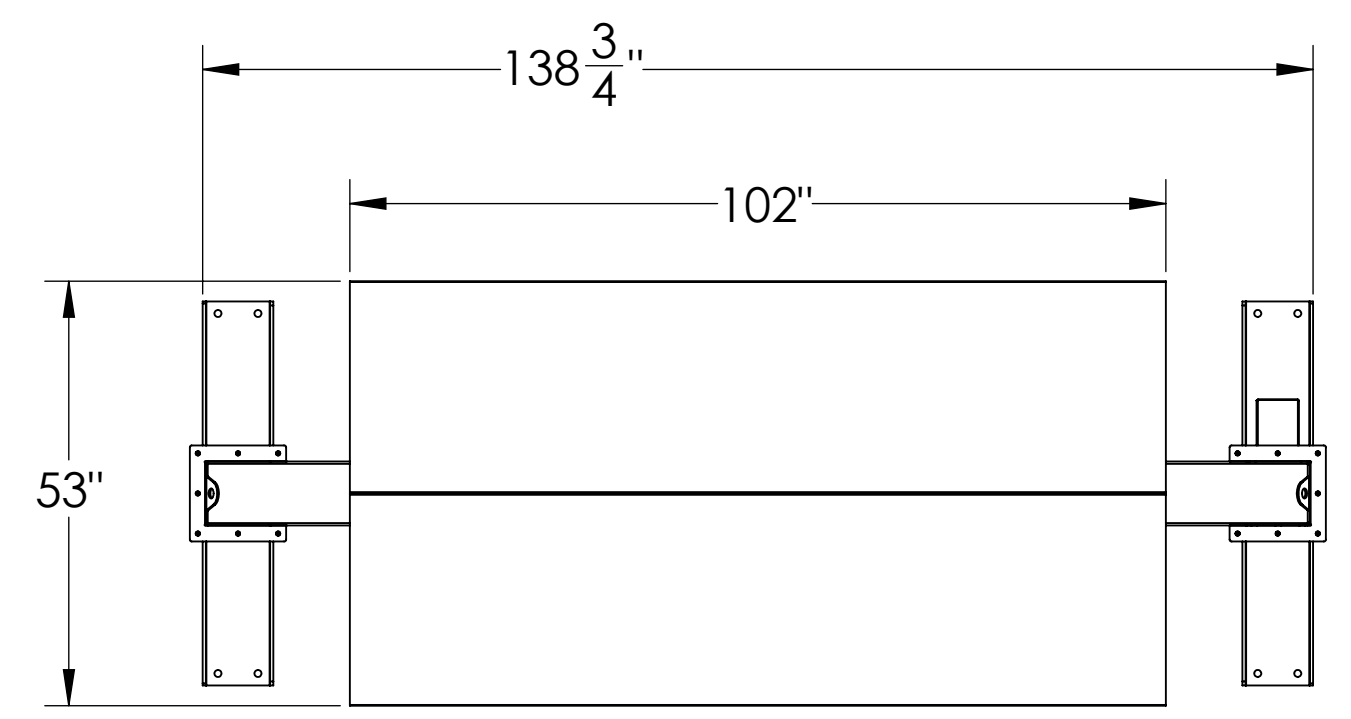

FOOT PRINT SECTION A-A

DISCHARGE FLANGE DETAIL B SCALE 1 : 8

\*OPTIONAL CRANE SLOTS, CURTAIN STRIPS & LIGHT FIXTURE AVAILABLE.

THIS DRAWING IS A CONFIDENTIAL DISCLOSURE AND IS LOANED TO RECALL AT ANY TIME WITH THE UNDERSTANDING THAT IT WILL NOT BE USED IN ANY WAY DETRIMENTAL TO THE INTERESTS OF IMPERIAL SYSTEMS.

DESIGN DATA:	HOOD VOLUME: 325 CU.FT. AIR FLOW: 850 CFM	DRAWN BY	DHE	DATE	10/26/20	WEIGHT (lbs)	
PAINT COLOR:		IMPERIAL FLAT BLACK					
FINISH:		ALL SHARP EDGES TO BE ROUNDED TO A SMOOTH RADIUS. ALL BURRS, WELD SPATTER AND ALL OTHER SHARP PROJECTION TO BE GROUND SMOOTH.					
UNLESS OTHERWISE SPECIFIED:		1. NO BURRS OR SHARP EDGES 2. MACHINED SURFACES 125 Ra, DRILLED HOLES 250 Ra					
TOLERANCES UNLESS OTHERWISE INDICATED		.0 ± .020 FRACTIONS: ± 1/8 .00 ± .010 ANGULAR: ± 1° .000 ± .005					
SCALE	1:24	DO NOT SCALE DRAWING		SHEET	1 OF 1	DRW. NO.	AP080408



7320 W. MARKET ST.  
MERCER, PA 16137  
T: 724-662-2801  
F: 724-662-2803  
www.isystemsweb.com

AIRPORT  
8FT X 4FT X 8FT

8 7 6 5 4 3 2 1